



**Transfert thermique et Echangeurs de chaleur & Phénomène de Transfert II**

Module : ..... Année : 21/20 Spécialité : ..... Groupe : ..... Durée : 60 min  
Nom et prénom : ..... : الاسم واللقب: ..... Matricule: .....

**Basic Heat-Transfer Relations**

Fourier's law of heat conduction:

$$q_x = -kA \frac{\partial T}{\partial x}$$

Characteristic thermal resistance for conduction =  $\Delta x/kA$

Characteristic thermal resistance for convection =  $1/hA$

Overall heat transfer =  $\Delta T_{\text{overall}} / \Sigma R_{\text{thermal}}$

Convection heat transfer from a surface:

$$q = hA(T_{\text{surface}} - T_{\text{free stream}}) \quad \text{for exterior flows}$$

$$q = hA(T_{\text{surface}} - T_{\text{fluid bulk}}) \quad \text{for flow in channels}$$

Forced convection:  $Nu = f(Re, Pr)$

Free convection:  $Nu = f(Gr, Pr)$

$$Re = \frac{\rho u x}{\mu} \quad Gr = \frac{\rho^2 g \beta \Delta T x^3}{\mu^2} \quad Pr = \frac{c_p \mu}{k}$$

$x$  = characteristic dimension

Blackbody emissive power,  $\frac{\text{energy emitted by blackbody}}{\text{area} \cdot \text{time}} = \sigma T^4$

Radiosity =  $\frac{\text{energy leaving surface}}{\text{area} \cdot \text{time}}$

Irradiation =  $\frac{\text{energy incident on surface}}{\text{area} \cdot \text{time}}$

Radiation shape factor  $F_{mn}$  = fraction of energy leaving surface  $m$  and arriving at surface  $n$

Reciprocity relation:  $A_m F_{mn} = A_n F_{nm}$

Radiation heat transfer from surface with area  $A_1$ , emissivity  $\epsilon_1$ , and temperature  $T_1(K)$  to large enclosure at temperature  $T_2(K)$ :

$$q = \sigma A_1 \epsilon_1 (T_1^4 - T_2^4)$$

LMTD method for heat exchangers :

$$q = UAF \Delta T_m$$

where  $F$  = factor for specific heat exchanger;  $\Delta T_m$  = LMTD for counterflow double-pipe heat exchanger with same inlet and exit temperatures

Effectiveness-NTU method for heat exchangers :

$$\epsilon = \frac{\text{Temperature difference for fluid with minimum value of } mc}{\text{Largest temperature difference in heat exchanger}}$$

$$NTU = \frac{UA}{C_{\min}} \quad \epsilon = f(NTU, C_{\min}/C_{\max})$$

*See List of Symbols on next page for definitions of terms.*



الجمهورية الجزائرية الديمقراطية الشعبية  
وزارة التعليم العالي والبحث العلمي  
جامعة الشهيد حمه لخضر الوادي  
كلية التكنولوجيا  
قسم هندسة الطرائق والصناعات البتر وكيميائية  
**Document autorisé**



**Transfert thermique et Echangeurs de chaleur & Phénomène de Transfert II**

Module : **UEM1.1** Année : 21/20 Spécialité : .....Groupe : ..... Durée : 60 min

Nom et prénom : .....: الاسم واللقب: ..... Matricule: .....

**Useful conversion factors**

Physical quantity	Symbol	SI to English conversion	English to SI conversion
Length	$L$	1 m = 3.2808 ft	1 ft = 0.3048 m
Area	$A$	1 m <sup>2</sup> = 10.7639 ft <sup>2</sup>	1 ft <sup>2</sup> = 0.092903 m <sup>2</sup>
Volume	$V$	1 m <sup>3</sup> = 35.3134 ft <sup>3</sup>	1 ft <sup>3</sup> = 0.028317 m <sup>3</sup>
Velocity	$v$	1 m/s = 3.2808 ft/s	1 ft/s = 0.3048 m/s
Density	$\rho$	1 kg/m <sup>3</sup> = 0.06243 lb <sub>m</sub> /ft <sup>3</sup>	1 lb <sub>m</sub> /ft <sup>3</sup> = 16.018 kg/m <sup>3</sup>
Force	$F$	1 N = 0.2248 lb <sub>f</sub>	1 lb <sub>f</sub> = 4.4482 N
Mass	$m$	1 kg = 2.20462 lb <sub>m</sub>	1 lb <sub>m</sub> = 0.45359237 kg
Pressure	$p$	1 N/m <sup>2</sup> = 1.45038 × 10 <sup>-4</sup> lb <sub>f</sub> /in <sup>2</sup>	1 lb <sub>f</sub> /in <sup>2</sup> = 6894.76 N/m <sup>2</sup>
Energy, heat	$q$	1 kJ = 0.94783 Btu	1 Btu = 1.05504 kJ
Heat flow	$q$	1 W = 3.4121 Btu/h	1 Btu/h = 0.29307 W
Heat flux per unit area	$q/A$	1 W/m <sup>2</sup> = 0.317 Btu/h · ft <sup>2</sup>	1 Btu/h · ft <sup>2</sup> = 3.154 W/m <sup>2</sup>
Heat flux per unit length	$q/L$	1 W/m = 1.0403 Btu/h · ft	1 Btu/h · ft = 0.9613 W/m
Heat generation per unit volume	$\dot{q}$	1 W/m <sup>3</sup> = 0.096623 Btu/h · ft <sup>3</sup>	1 Btu/h · ft <sup>3</sup> = 10.35 W/m <sup>3</sup>
Energy per unit mass	$q/m$	1 kJ/kg = 0.4299 Btu/lb <sub>m</sub>	1 Btu/lb <sub>m</sub> = 2.326 kJ/kg
Specific heat	$c$	1 kJ/kg · °C = 0.23884 Btu/lb <sub>m</sub> · °F	1 Btu/lb <sub>m</sub> · °F = 4.1869 kJ/kg · °C
Thermal conductivity	$k$	1 W/m · °C = 0.5778 Btu/h · ft · °F	1 Btu/h · ft · °F = 1.7307 W/m · °C
Convection heat-transfer coefficient	$h$	1 W/m <sup>2</sup> · °C = 0.1761 Btu/h · ft <sup>2</sup> · °F	1 Btu/h · ft <sup>2</sup> · °F = 5.6782 W/m <sup>2</sup> · °C
Dynamic		1 kg/m · s = 0.672 lb <sub>m</sub> /ft · s	
Viscosity	$\mu$	= 2419.2 lb <sub>m</sub> /ft · h	1 lb <sub>m</sub> /ft · s = 1.4881 kg/m · s
Kinematic viscosity and thermal diffusivity	$\nu, \alpha$	1 m <sup>2</sup> /s = 10.7639 ft <sup>2</sup> /s	1 ft <sup>2</sup> /s = 0.092903 m <sup>2</sup> /s

**Important physical constants**

Avogadro's number	$N_0 = 6.022045 \times 10^{26}$ molecules/kg mol
Universal gas constant	$R = 1545.35$ ft · lbf/lb <sub>m</sub> · mol · °R = 8314.41 J/kg mol · K = 1.986 Btu/lb <sub>m</sub> · mol · °R = 1.986 kcal/kg mol · K
Planck's constant	$h = 6.626176 \times 10^{-34}$ J · sec
Boltzmann's constant	$k = 1.380662 \times 10^{-23}$ J/molecule · K = 8.6173 × 10 <sup>-5</sup> eV/molecule · K
Speed of light in vacuum	$c = 2.997925 \times 10^8$ m/s
Standard gravitational acceleration	$g = 32.174$ ft/s <sup>2</sup> = 9.80665 m/s <sup>2</sup>
Electron mass	$m_e = 9.1095 \times 10^{-31}$ kg
Charge on the electron	$e = 1.602189 \times 10^{-19}$ C
Stefan-Boltzmann constant	$\sigma = 0.1714 \times 10^{-8}$ Btu/hr · ft <sup>2</sup> · R <sup>4</sup> = 5.669 × 10 <sup>-8</sup> W/m <sup>2</sup> · K <sup>4</sup>
1 atm	= 14.69595 lbf/in <sup>2</sup> = 760 mmHg at 32°F = 29.92 inHg at 32°F = 2116.21 lbf/ft <sup>2</sup> = 1.01325 × 10 <sup>5</sup> N/m <sup>2</sup>



**Transfert thermique et Echangeurs de chaleur & Phénomène de Transfert II**

Module : **UEM1.1** Année : 21/20 Spécialité : .....Groupe : ..... Durée : 60 min

Nom et prénom : .....:الاسم واللقب:..... Matricule:.....

**Distributions de température et flux de chaleur pour les ailettes de section uniforme**

Case	Tip Condition ( $x = L$ )	Temperature Distribution $\theta/\theta_b$	Fin Heat Transfer Rate $q_f$
A	Convection: $h\theta(L) = -kd\theta/dx _{x=L}$	$\frac{\cosh m(L-x) + (h/mk) \sinh m(L-x)}{\cosh mL + (h/mk) \sinh mL}$ (3.75)	$M \frac{\sinh mL + (h/mk) \cosh mL}{\cosh mL + (h/mk) \sinh mL}$ (3.77)
B	Adiabatic: $d\theta/dx _{x=L} = 0$	$\frac{\cosh m(L-x)}{\cosh mL}$ (3.80)	$M \tanh mL$ (3.81)
C	Prescribed temperature: $\theta(L) = \theta_L$	$\frac{(\theta_L/\theta_b) \sinh mx + \sinh m(L-x)}{\sinh mL}$ (3.82)	$M \frac{(\cosh mL - \theta_L/\theta_b)}{\sinh mL}$ (3.83)
D	Infinite fin ( $L \rightarrow \infty$ ): $\theta(L) = 0$	$e^{-mx}$ (3.84)	$M$ (3.85)

$\theta \equiv T - T_\infty$        $m^2 \equiv hP/kA_c$   
 $\theta_b = \theta(0) = T_b - T_\infty$        $M \equiv \sqrt{hPkA_c} \theta_b$

**Hyperbolic Functions**

x	sinh x	cosh x	tanh x	x	sinh x	cosh x	tanh x
0.00	0.0000	1.0000	0.00000	2.00	3.6269	3.7622	0.96403
0.10	0.1002	1.0050	0.09967	2.10	4.0219	4.1443	0.97045
0.20	0.2013	1.0201	0.19738	2.20	4.4571	4.5679	0.97574
0.30	0.3045	1.0453	0.29131	2.30	4.9370	5.0372	0.98010
0.40	0.4108	1.0811	0.37995	2.40	5.4662	5.5569	0.98367
0.50	0.5211	1.1276	0.46212	2.50	6.0502	6.1323	0.98661
0.60	0.6367	1.1855	0.53705	2.60	6.6947	6.7690	0.98903
0.70	0.7586	1.2552	0.60437	2.70	7.4063	7.4735	0.99101
0.80	0.8881	1.3374	0.66404	2.80	8.1919	8.2527	0.99263
0.90	1.0265	1.4331	0.71630	2.90	9.0596	9.1146	0.99396
1.00	1.1752	1.5431	0.76159	3.00	10.018	10.068	0.99505
1.10	1.3356	1.6685	0.80050	3.50	16.543	16.573	0.99818
1.20	1.5095	1.8107	0.83365	4.00	27.290	27.308	0.99933
1.30	1.6984	1.9709	0.86172	4.50	45.003	45.014	0.99975
1.40	1.9043	2.1509	0.88535	5.00	74.203	74.210	0.99991
1.50	2.1293	2.3524	0.90515	6.00	201.71	201.72	0.99999
1.60	2.3756	2.5775	0.92167	7.00	548.32	548.32	1.0000
1.70	2.6456	2.8283	0.93541	8.00	1490.5	1490.5	1.0000
1.80	2.9422	3.1075	0.94681	9.00	4051.5	4051.5	1.0000
1.90	3.2682	3.4177	0.95624	10.000	11013	11013	1.0000

<sup>1</sup>The hyperbolic functions are defined as

$$\sinh x = \frac{1}{2}(e^x - e^{-x}) \quad \cosh x = \frac{1}{2}(e^x + e^{-x}) \quad \tanh x = \frac{e^x - e^{-x}}{e^x + e^{-x}} = \frac{\sinh x}{\cosh x}$$

The derivatives of the hyperbolic functions of the variable  $u$  are given as

$$\frac{d}{dx}(\sinh u) = (\cosh u) \frac{du}{dx} \quad \frac{d}{dx}(\cosh u) = (\sinh u) \frac{du}{dx} \quad \frac{d}{dx}(\tanh u) = \left(\frac{1}{\cosh^2 u}\right) \frac{du}{dx}$$



**Document autorisé**

**Transfert thermique et Echangeurs de chaleur & Phénomène de Transfert II**

Module : **UEM1.1** Année : 21/20 Spécialité : .....Groupe : ..... Durée : 60 min

Nom et prénom : .....:الاسم واللقب:..... Matricule:.....

**Efficiency of common fin shapes**

**Straight Fins**

**Rectangular<sup>a</sup>**

$$A_f = 2wL_c$$

$$L_c = L + (t/2)$$

$$A_p = tL$$

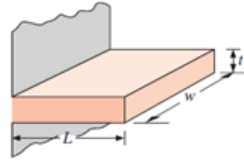

$$\eta_f = \frac{\tanh mL_c}{mL_c}$$

**Triangular<sup>a</sup>**

$$A_f = 2w[L^2 + (t/2)^2]^{1/2}$$

$$A_p = (t/2)L$$

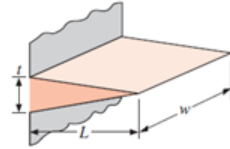

$$\eta_f = \frac{1}{mL} \frac{I_1(2mL)}{I_0(2mL)}$$

**Parabolic<sup>a</sup>**

$$A_f = w[C_1L + (L^2/t)\ln(tL + C_1)]$$

$$C_1 = [1 + (tL)^2]^{1/2}$$

$$A_p = (t/3)L$$

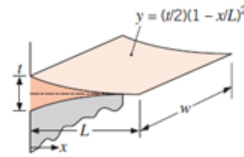

$$\eta_f = \frac{2}{[4(mL)^2 + 1]^{1/2} + 1}$$

**Circular Fin**

**Rectangular<sup>a</sup>**

$$A_f = 2\pi(r_{2c}^2 - r_1^2)$$

$$r_{2c} = r_2 + (t/2)$$

$$V = \pi(r_{2c}^2 - r_1^2)t$$

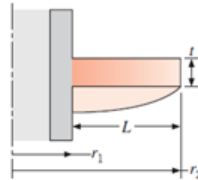

$$\eta_f = C_2 \frac{K_1(mr_1)I_1(mr_{2c}) - I_1(mr_1)K_1(mr_{2c})}{I_0(mr_1)K_1(mr_{2c}) + K_0(mr_1)I_1(mr_{2c})}$$

$$C_2 = \frac{(2r_1/m)}{(r_{2c}^2 - r_1^2)}$$

**Pin Fins**

**Rectangular<sup>b</sup>**

$$A_f = \pi DL_c$$

$$L_c = L + (D/4)$$

$$V = (\pi D^2/4)L$$

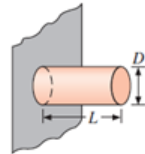

$$\eta_f = \frac{\tanh mL_c}{mL_c}$$

**Triangular<sup>b</sup>**

$$A_f = \frac{\pi D}{2} [L^2 + (D/2)^2]^{1/2}$$

$$V = (\pi/12)D^2L$$

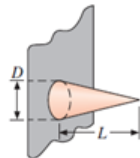

$$\eta_f = \frac{2}{mL} \frac{I_2(2mL)}{I_1(2mL)}$$

**Parabolic<sup>b</sup>**

$$A_f = \frac{\pi L^3}{8D} \{C_3C_4 - \frac{L}{2D} \ln [(2DC_4/L) + C_3]\}$$

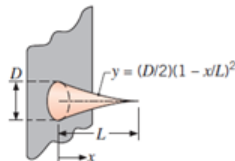

$$\eta_f = \frac{2}{[4/9(mL)^2 + 1]^{1/2} + 1}$$

$$C_3 = 1 + 2(D/L)^2$$

$$C_4 = [1 + (D/L)^2]^{1/2}$$

$$V = (\pi/20)D^2L$$

<sup>a</sup> $m = (2h/kt)^{1/2}$ ,  
<sup>b</sup> $m = (4h/kD)^{1/2}$ .



*Document autorisé*

**Transfert thermique et Echangeurs de chaleur & Phénomène de Transfert II**

Module : **UEM1.1** Année : 21/20 Spécialité : .....Groupe : ..... Durée : 60 min

Nom et prénom : .....:الاسم واللقب:..... Matricule:.....

**Diagrammes du facteur de correction F pour les échangeurs de chaleur à Faisceau et calandre (Shell and Tube) et à courant croisé (Cross-Flow).**

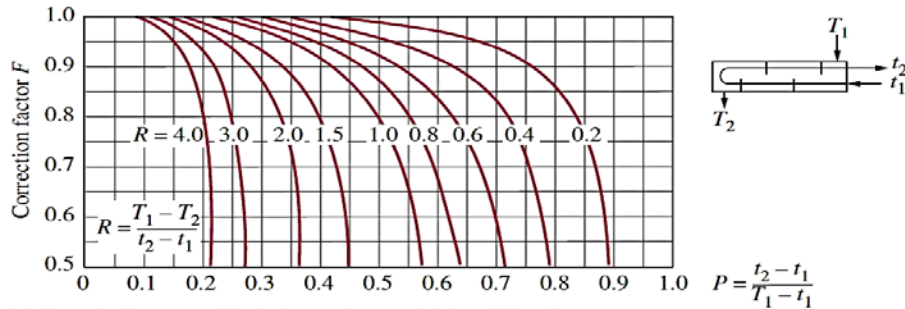

(a) One-shell pass and 2, 4, 6, etc. (any multiple of 2), tube passes

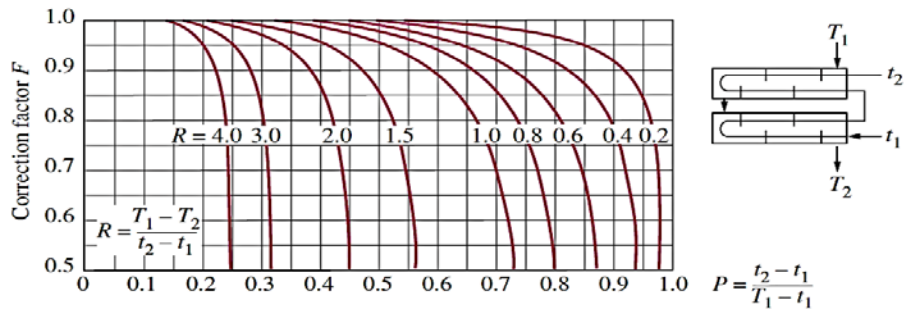

(b) Two-shell passes and 4, 8, 12, etc. (any multiple of 4), tube passes

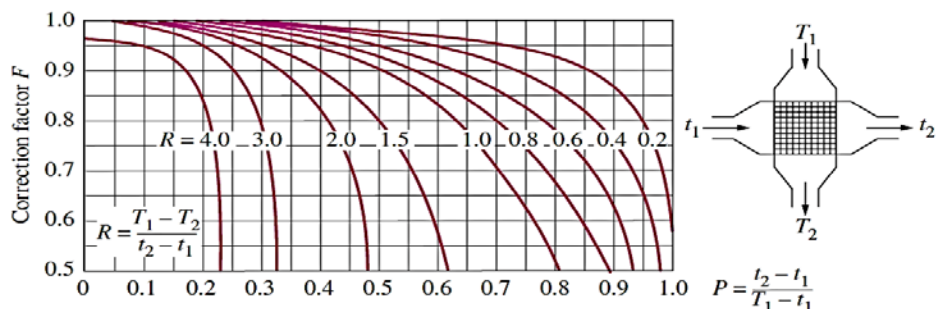

(c) Single-pass cross-flow with both fluids *unmixed*

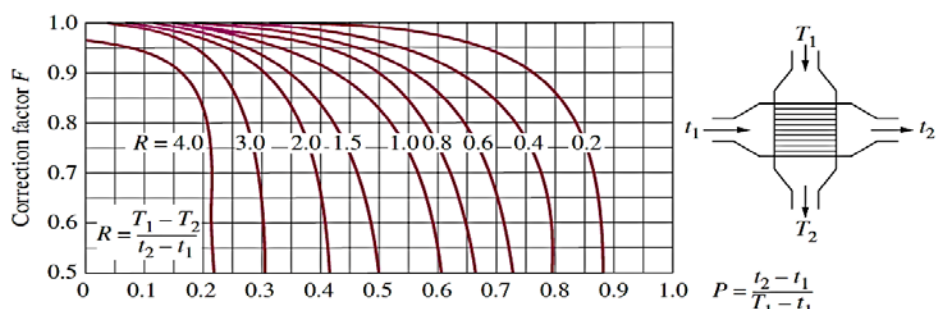

(d) Single-pass cross-flow with one fluid *mixed* and the other *unmixed*



**Document autorisé**

**Transfert thermique et Echangeurs de chaleur & Phénomène de Transfert II**

Module : **UEM1.1** Année : 21/20 Spécialité : .....Groupe : ..... Durée : 60 min

Nom et prénom : .....:الاسم واللقب:..... Matricule:.....

**Abaques NUT = f(η) pour les échangeurs**

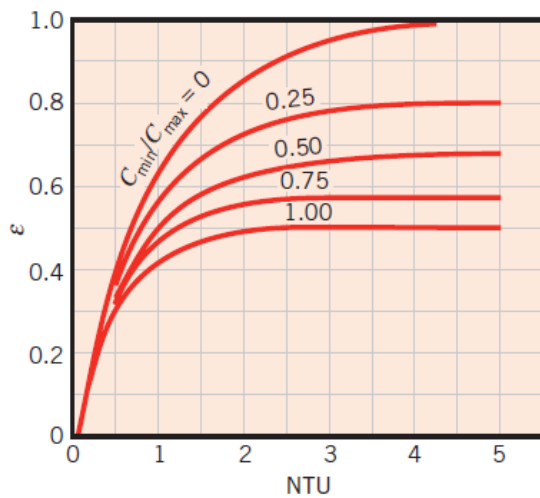

**Echangeur co-courant**

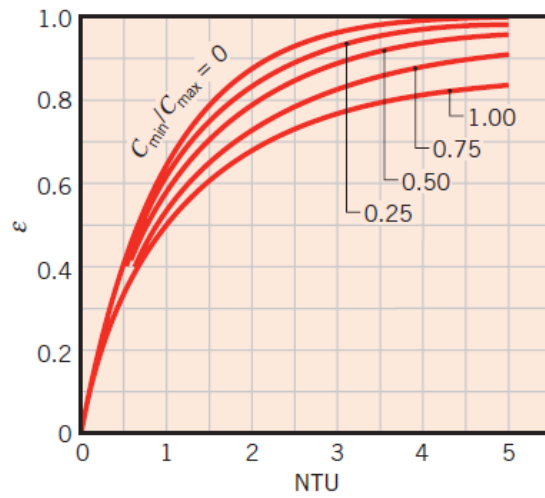

**Echangeur contre-courant**

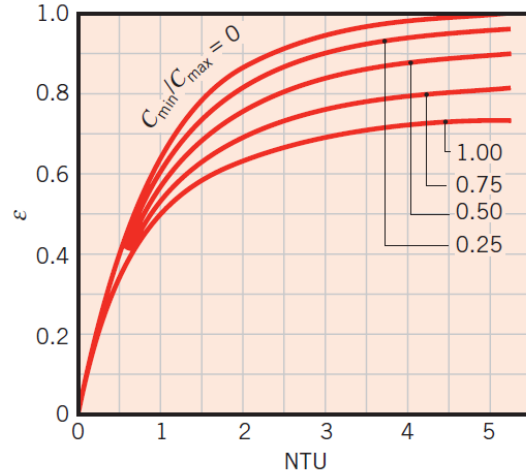
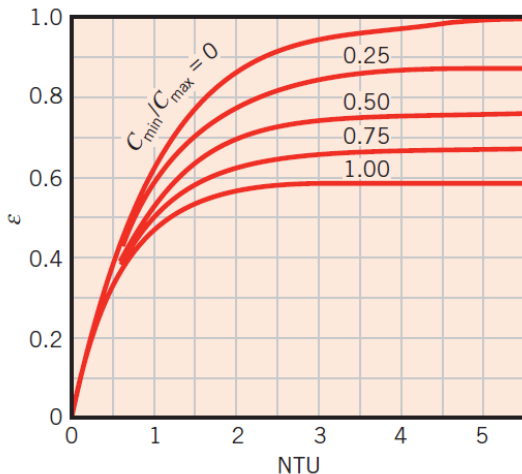
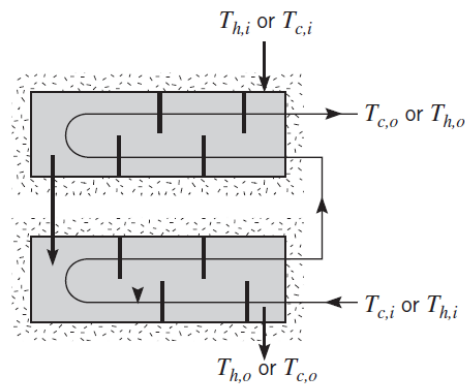
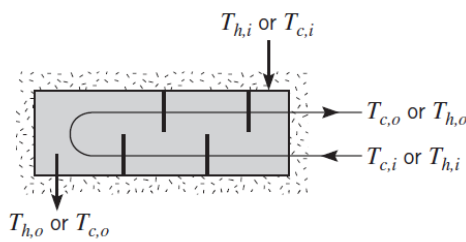



*Document autorisé*

**Transfert thermique et Echangeurs de chaleur & Phénomène de Transfert II**

Module : **UEM1.1** Année : 21/20 Spécialité : .....Groupe : ..... Durée : 60 min

Nom et prénom : .....: الاسم واللقب: ..... Matricule: .....

**Abaques NUT =  $f(\eta)$  pour les échangeurs**

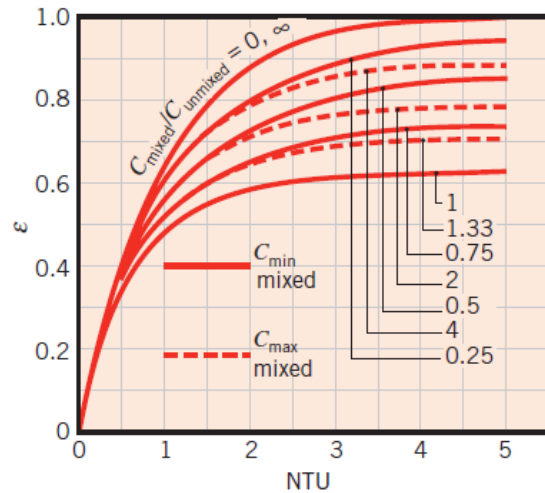
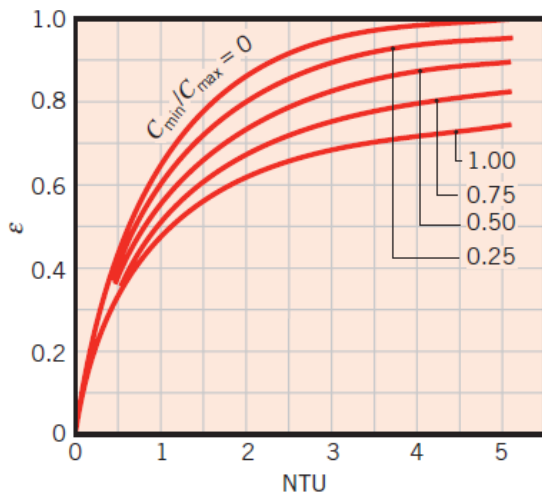
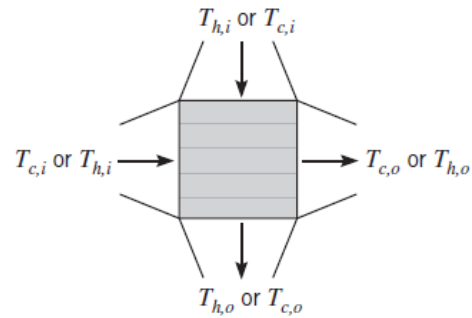
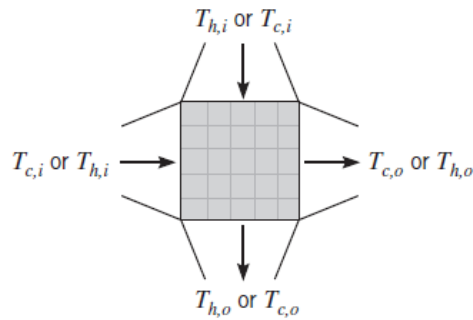



**Document autorisé**

**Transfert thermique et Echangeurs de chaleur & Phénomène de Transfert II**

Module : ..... Année : 21/20 Spécialité : ..... Groupe : ..... Durée : 60 min  
Nom et prénom : ..... الاسم واللقب : ..... Matricule : .....

Flow Arrangement	Relation
Parallel flow	$\varepsilon = \frac{1 - \exp[-NTU(1 + C_r)]}{1 + C_r}$ (6.30.a)
Counterflow	$\varepsilon = \frac{1 - \exp[-NTU(1 - C_r)]}{1 - C_r \exp[-NTU(1 - C_r)]}$ ( $C_r < 1$ )
	$\varepsilon = \frac{NTU}{1 + NTU}$ ( $C_r = 1$ ) (6.31.a)
Shell-and-tube	
One shell pass (2, 4, ... tube passes)	$\varepsilon_1 = 2 \left[ 1 + C_r + (1 + C_r^2)^{1/2} \times \frac{1 + \exp[-(NTU)_1(1 + C_r^2)^{1/2}]}{1 - \exp[-(NTU)_1(1 + C_r^2)^{1/2}]} \right]^{-1}$ (6.32.a)
$n$ shell passes ( $2n, 4n, \dots$ tube passes)	$\varepsilon = \left[ \left( \frac{1 - \varepsilon_1 C_r}{1 - \varepsilon_1} \right)^n - 1 \right] \left[ \left( \frac{1 - \varepsilon_1 C_r}{1 - \varepsilon_1} \right)^n - C_r \right]^{-1}$ (6.33.a)
Cross-flow (single pass)	
Both fluids unmixed	$\varepsilon = 1 - \exp \left[ \left( \frac{1}{C_r} \right) (NTU)^{0.22} \{ \exp[-C_r(NTU)^{0.78}] - 1 \} \right]$ (6.34.a)
$C_{max}$ (mixed), $C_{min}$ (unmixed)	$\varepsilon = \left( \frac{1}{C_r} \right) (1 - \exp \{ -C_r [1 - \exp(-NTU)] \})$ (6.35.a)
$C_{min}$ (mixed), $C_{max}$ (unmixed)	$\varepsilon = 1 - \exp(-C_r^{-1} \{ 1 - \exp[-C_r(NTU)] \})$ (6.36.a)
All exchangers ( $C_r = 0$ )	$\varepsilon = 1 - \exp(-NTU)$ (6.37.a)

Flow Arrangement	Relation
Parallel flow	$NTU = -\frac{\ln[1 - \varepsilon(1 + C_r)]}{1 + C_r}$ (6.30.b)
Counterflow	$NTU = \frac{1}{C_r - 1} \ln \left( \frac{\varepsilon - 1}{\varepsilon C_r - 1} \right)$ ( $C_r < 1$ )
	$NTU = \frac{\varepsilon}{1 - \varepsilon}$ ( $C_r = 1$ ) (6.31.b)
Shell-and-tube	
One shell pass (2, 4, ... tube passes)	$(NTU)_1 = -(1 + C_r^2)^{-1/2} \ln \left( \frac{E - 1}{E + 1} \right)$ $E = \frac{2/\varepsilon_1 - (1 + C_r)}{(1 + C_r^2)^{1/2}}$ (6.32.b)
$n$ shell passes ( $2n, 4n, \dots$ tube passes)	Use Equations 11.30b and 11.30c with $\varepsilon_1 = \frac{F - 1}{F - C_r}$ $F = \left( \frac{\varepsilon C_r - 1}{\varepsilon - 1} \right)^{1/n}$ $NTU = n(NTU)_1$ (6.33.b)
Cross-flow (single pass)	
$C_{max}$ (mixed), $C_{min}$ (unmixed)	$NTU = -\ln \left[ 1 + \left( \frac{1}{C_r} \right) \ln(1 - \varepsilon C_r) \right]$ (6.34.b)
$C_{min}$ (mixed), $C_{max}$ (unmixed)	$NTU = -\left( \frac{1}{C_r} \right) \ln[C_r \ln(1 - \varepsilon) + 1]$ (6.35.b)
All exchangers ( $C_r = 0$ )	$NTU = -\ln(1 - \varepsilon)$ (6.36.b)





الجمهورية الجزائرية الديمقراطية الشعبية  
وزارة التعليم العالي والبحث العلمي  
جامعة الشهيد حمه لخضر الوادي  
كلية التكنولوجيا  
قسم هندسة الطرائق والصناعات البتر وكيميائية



## Document autorisé

### Transfert thermique et Echangeurs de chaleur & Phénomène de Transfert II

Module : ..... Année : 21/20 Spécialité : ..... Groupe : ..... Durée : 60 min  
Nom et prénom : ..... الاسم واللقب : ..... Matricule : .....

#### Properties of air at 1 atm pressure

Temp. $T, ^\circ\text{C}$	Density $\rho, \text{kg/m}^3$	Specific Heat $c_p, \text{J/kg}\cdot\text{K}$	Thermal Conductivity $k, \text{W/m}\cdot\text{K}$	Thermal Diffusivity $\alpha, \text{m}^2/\text{s}$	Dynamic Viscosity $\mu, \text{kg/m}\cdot\text{s}$	Kinematic Viscosity $\nu, \text{m}^2/\text{s}$	Prandtl Number Pr
-150	2.866	983	0.01171	$4.158 \times 10^{-6}$	$8.636 \times 10^{-6}$	$3.013 \times 10^{-6}$	0.7246
-100	2.038	966	0.01582	$8.036 \times 10^{-6}$	$1.189 \times 10^{-5}$	$5.837 \times 10^{-6}$	0.7263
-50	1.582	999	0.01979	$1.252 \times 10^{-5}$	$1.474 \times 10^{-5}$	$9.319 \times 10^{-6}$	0.7440
-40	1.514	1002	0.02057	$1.356 \times 10^{-5}$	$1.527 \times 10^{-5}$	$1.008 \times 10^{-5}$	0.7436
-30	1.451	1004	0.02134	$1.465 \times 10^{-5}$	$1.579 \times 10^{-5}$	$1.087 \times 10^{-5}$	0.7425
-20	1.394	1005	0.02211	$1.578 \times 10^{-5}$	$1.630 \times 10^{-5}$	$1.169 \times 10^{-5}$	0.7408
-10	1.341	1006	0.02288	$1.696 \times 10^{-5}$	$1.680 \times 10^{-5}$	$1.252 \times 10^{-5}$	0.7387
0	1.292	1006	0.02364	$1.818 \times 10^{-5}$	$1.729 \times 10^{-5}$	$1.338 \times 10^{-5}$	0.7362
5	1.269	1006	0.02401	$1.880 \times 10^{-5}$	$1.754 \times 10^{-5}$	$1.382 \times 10^{-5}$	0.7350
10	1.246	1006	0.02439	$1.944 \times 10^{-5}$	$1.778 \times 10^{-5}$	$1.426 \times 10^{-5}$	0.7336
15	1.225	1007	0.02476	$2.009 \times 10^{-5}$	$1.802 \times 10^{-5}$	$1.470 \times 10^{-5}$	0.7323
20	1.204	1007	0.02514	$2.074 \times 10^{-5}$	$1.825 \times 10^{-5}$	$1.516 \times 10^{-5}$	0.7309
25	1.184	1007	0.02551	$2.141 \times 10^{-5}$	$1.849 \times 10^{-5}$	$1.562 \times 10^{-5}$	0.7296
30	1.164	1007	0.02588	$2.208 \times 10^{-5}$	$1.872 \times 10^{-5}$	$1.608 \times 10^{-5}$	0.7282
35	1.145	1007	0.02625	$2.277 \times 10^{-5}$	$1.895 \times 10^{-5}$	$1.655 \times 10^{-5}$	0.7268
40	1.127	1007	0.02662	$2.346 \times 10^{-5}$	$1.918 \times 10^{-5}$	$1.702 \times 10^{-5}$	0.7255
45	1.109	1007	0.02699	$2.416 \times 10^{-5}$	$1.941 \times 10^{-5}$	$1.750 \times 10^{-5}$	0.7241
50	1.092	1007	0.02735	$2.487 \times 10^{-5}$	$1.963 \times 10^{-5}$	$1.798 \times 10^{-5}$	0.7228
60	1.059	1007	0.02808	$2.632 \times 10^{-5}$	$2.008 \times 10^{-5}$	$1.896 \times 10^{-5}$	0.7202
70	1.028	1007	0.02881	$2.780 \times 10^{-5}$	$2.052 \times 10^{-5}$	$1.995 \times 10^{-5}$	0.7177
80	0.9994	1008	0.02953	$2.931 \times 10^{-5}$	$2.096 \times 10^{-5}$	$2.097 \times 10^{-5}$	0.7154
90	0.9718	1008	0.03024	$3.086 \times 10^{-5}$	$2.139 \times 10^{-5}$	$2.201 \times 10^{-5}$	0.7132
100	0.9458	1009	0.03095	$3.243 \times 10^{-5}$	$2.181 \times 10^{-5}$	$2.306 \times 10^{-5}$	0.7111
120	0.8977	1011	0.03235	$3.565 \times 10^{-5}$	$2.264 \times 10^{-5}$	$2.522 \times 10^{-5}$	0.7073
140	0.8542	1013	0.03374	$3.898 \times 10^{-5}$	$2.345 \times 10^{-5}$	$2.745 \times 10^{-5}$	0.7041
160	0.8148	1016	0.03511	$4.241 \times 10^{-5}$	$2.420 \times 10^{-5}$	$2.975 \times 10^{-5}$	0.7014
180	0.7788	1019	0.03646	$4.593 \times 10^{-5}$	$2.504 \times 10^{-5}$	$3.212 \times 10^{-5}$	0.6992
200	0.7459	1023	0.03779	$4.954 \times 10^{-5}$	$2.577 \times 10^{-5}$	$3.455 \times 10^{-5}$	0.6974
250	0.6746	1033	0.04104	$5.890 \times 10^{-5}$	$2.760 \times 10^{-5}$	$4.091 \times 10^{-5}$	0.6946
300	0.6158	1044	0.04418	$6.871 \times 10^{-5}$	$2.934 \times 10^{-5}$	$4.765 \times 10^{-5}$	0.6935
350	0.5664	1056	0.04721	$7.892 \times 10^{-5}$	$3.101 \times 10^{-5}$	$5.475 \times 10^{-5}$	0.6937
400	0.5243	1069	0.05015	$8.951 \times 10^{-5}$	$3.261 \times 10^{-5}$	$6.219 \times 10^{-5}$	0.6948
450	0.4880	1081	0.05298	$1.004 \times 10^{-4}$	$3.415 \times 10^{-5}$	$6.997 \times 10^{-5}$	0.6965
500	0.4565	1093	0.05572	$1.117 \times 10^{-4}$	$3.563 \times 10^{-5}$	$7.806 \times 10^{-5}$	0.6986
600	0.4042	1115	0.06093	$1.352 \times 10^{-4}$	$3.846 \times 10^{-5}$	$9.515 \times 10^{-5}$	0.7037
700	0.3627	1135	0.06581	$1.598 \times 10^{-4}$	$4.111 \times 10^{-5}$	$1.133 \times 10^{-4}$	0.7092
800	0.3289	1153	0.07037	$1.855 \times 10^{-4}$	$4.362 \times 10^{-5}$	$1.326 \times 10^{-4}$	0.7149
900	0.3008	1169	0.07465	$2.122 \times 10^{-4}$	$4.600 \times 10^{-5}$	$1.529 \times 10^{-4}$	0.7206
1000	0.2772	1184	0.07868	$2.398 \times 10^{-4}$	$4.826 \times 10^{-5}$	$1.741 \times 10^{-4}$	0.7260
1500	0.1990	1234	0.09599	$3.908 \times 10^{-4}$	$5.817 \times 10^{-5}$	$2.922 \times 10^{-4}$	0.7478
2000	0.1553	1264	0.11113	$5.664 \times 10^{-4}$	$6.630 \times 10^{-5}$	$4.270 \times 10^{-4}$	0.7539

Note: For ideal gases, the properties  $c_p$ ,  $k$ ,  $\mu$ , and Pr are independent of pressure. The properties  $\rho$ ,  $\nu$ , and  $\alpha$  at a pressure  $P$  (in atm) other than 1 atm are determined by multiplying the values of  $\rho$  at the given temperature by  $P$  and by dividing  $\nu$  and  $\alpha$  by  $P$ .



الجمهورية الجزائرية الديمقراطية الشعبية  
وزارة التعليم العالي والبحث العلمي  
جامعة الشهيد حمه لخضر الوادي  
كلية التكنولوجيا  
قسم هندسة الطرائق والصناعات البتر وكيميائية



## Document autorisé

### Transfert thermique et Echangeurs de chaleur & Phénomène de Transfert II

Module : **UEM1.1** Année : 21/20 Spécialité : .....Groupe : ..... Durée : 60 min

Nom et prénom : .....:الاسم واللقب:..... Matricule:.....

#### Saturated Liquids

$T$ (K)	$\rho$ (kg/m <sup>3</sup> )	$c_p$ (kJ/kg·K)	$\mu \cdot 10^2$ (N·s/m <sup>2</sup> )	$\nu \cdot 10^6$ (m <sup>2</sup> /s)	$k \cdot 10^3$ (W/m·K)	$\alpha \cdot 10^7$ (m <sup>2</sup> /s)	$Pr$	$\beta \cdot 10^3$ (K <sup>-1</sup> )
<b>Engine Oil (Unused)</b>								
273	899.1	1.796	385	4280	147	0.910	47,000	0.70
280	895.3	1.827	217	2430	144	0.880	27,500	0.70
290	890.0	1.868	99.9	1120	145	0.872	12,900	0.70
300	884.1	1.909	48.6	550	145	0.859	6400	0.70
310	877.9	1.951	25.3	288	145	0.847	3400	0.70
320	871.8	1.993	14.1	161	143	0.823	1965	0.70
330	865.8	2.035	8.36	96.6	141	0.800	1205	0.70
340	859.9	2.076	5.31	61.7	139	0.779	793	0.70
350	853.9	2.118	3.56	41.7	138	0.763	546	0.70
360	847.8	2.161	2.52	29.7	138	0.753	395	0.70
370	841.8	2.206	1.86	22.0	137	0.738	300	0.70
380	836.0	2.250	1.41	16.9	136	0.723	233	0.70
390	830.6	2.294	1.10	13.3	135	0.709	187	0.70
400	825.1	2.337	0.874	10.6	134	0.695	152	0.70
410	818.9	2.381	0.698	8.52	133	0.682	125	0.70
420	812.1	2.427	0.564	6.94	133	0.675	103	0.70
430	806.5	2.471	0.470	5.83	132	0.662	88	0.70
<b>Ethylene Glycol [C<sub>2</sub>H<sub>4</sub>(OH)<sub>2</sub>]</b>								
273	1130.8	2.294	6.51	57.6	242	0.933	617	0.65
280	1125.8	2.323	4.20	37.3	244	0.933	400	0.65
290	1118.8	2.368	2.47	22.1	248	0.936	236	0.65
300	1114.4	2.415	1.57	14.1	252	0.939	151	0.65
310	1103.7	2.460	1.07	9.65	255	0.939	103	0.65
320	1096.2	2.505	0.757	6.91	258	0.940	73.5	0.65
330	1089.5	2.549	0.561	5.15	260	0.936	55.0	0.65
340	1083.8	2.592	0.431	3.98	261	0.929	42.8	0.65
350	1079.0	2.637	0.342	3.17	261	0.917	34.6	0.65
360	1074.0	2.682	0.278	2.59	261	0.906	28.6	0.65
370	1066.7	2.728	0.228	2.14	262	0.900	23.7	0.65
373	1058.5	2.742	0.215	2.03	263	0.906	22.4	0.65
<b>Glycerin [C<sub>3</sub>H<sub>5</sub>(OH)<sub>3</sub>]</b>								
273	1276.0	2.261	1060	8310	282	0.977	85,000	0.47
280	1271.9	2.298	534	4200	284	0.972	43,200	0.47
290	1265.8	2.367	185	1460	286	0.955	15,300	0.48
300	1259.9	2.427	79.9	634	286	0.935	6780	0.48
310	1253.9	2.490	35.2	281	286	0.916	3060	0.49
320	1247.2	2.564	21.0	168	287	0.897	1870	0.50



الجمهورية الجزائرية الديمقراطية الشعبية  
وزارة التعليم العالي والبحث العلمي  
جامعة الشهيد حمه لخضر الوادي  
كلية التكنولوجيا  
قسم هندسة الطرائق والصناعات البتر وكيميائية  
**Document autorisé**



**Transfert thermique et Echangeurs de chaleur & Phénomène de Transfert II**

Module : **UEM1.1** Année : 21/20 Spécialité : .....Groupe : ..... Durée : 60 min

Nom et prénom : .....: الاسم واللقب: ..... Matricule: .....

Thermophysical Properties of Saturated Water<sup>a</sup>

Temperature, $T$ (K)	Pressure, $p$ (bars) <sup>b</sup>	Specific Volume (m <sup>3</sup> /kg)		Heat of Vaporization, $h_{fg}$ (kJ/kg)	Specific Heat (kJ/kg · K)		Viscosity (N · s/m <sup>2</sup> )		Thermal Conductivity (W/m · K)		Prandtl Number		Surface Tension, $\sigma_f \cdot 10^3$ (N/m)	Expansion Coefficient, $\beta_f \cdot 10^6$ (K <sup>-1</sup> )	Temperature, $T$ (K)
		$v_f \cdot 10^3$	$v_g$		$c_{p,f}$	$c_{p,g}$	$\mu_f \cdot 10^6$	$\mu_g \cdot 10^6$	$k_f \cdot 10^3$	$k_g \cdot 10^3$	$Pr_f$	$Pr_g$			
273.15	0.00611	1.000	206.3	2502	4.217	1.854	1750	8.02	569	18.2	12.99	0.815	75.5	-68.05	273.15
275	0.00697	1.000	181.7	2497	4.211	1.855	1652	8.09	574	18.3	12.22	0.817	75.3	-32.74	275
280	0.00990	1.000	130.4	2485	4.198	1.858	1422	8.29	582	18.6	10.26	0.825	74.8	46.04	280
285	0.01387	1.000	99.4	2473	4.189	1.861	1225	8.49	590	18.9	8.81	0.833	74.3	114.1	285
290	0.01917	1.001	69.7	2461	4.184	1.864	1080	8.69	598	19.3	7.56	0.841	73.7	174.0	290
295	0.02617	1.002	51.94	2449	4.181	1.868	959	8.89	606	19.5	6.62	0.849	72.7	227.5	295
300	0.03531	1.003	39.13	2438	4.179	1.872	855	9.09	613	19.6	5.83	0.857	71.7	276.1	300
305	0.04712	1.005	29.74	2426	4.178	1.877	769	9.29	620	20.1	5.20	0.865	70.9	320.6	305
310	0.06221	1.007	22.93	2414	4.178	1.882	695	9.49	628	20.4	4.62	0.873	70.0	361.9	310
315	0.08132	1.009	17.82	2402	4.179	1.888	631	9.69	634	20.7	4.16	0.883	69.2	400.4	315
320	0.1053	1.011	13.98	2390	4.180	1.895	577	9.89	640	21.0	3.77	0.894	68.3	436.7	320
325	0.1351	1.013	11.06	2378	4.182	1.903	528	10.09	645	21.3	3.42	0.901	67.5	471.2	325
330	0.1719	1.016	8.82	2366	4.184	1.911	489	10.29	650	21.7	3.15	0.908	66.6	504.0	330
335	0.2167	1.018	7.09	2354	4.186	1.920	453	10.49	656	22.0	2.88	0.916	65.8	535.5	335
340	0.2713	1.021	5.74	2342	4.188	1.930	420	10.69	660	22.3	2.66	0.925	64.9	566.0	340
345	0.3372	1.024	4.683	2329	4.191	1.941	389	10.89	664	22.6	2.45	0.933	64.1	595.4	345
350	0.4163	1.027	3.846	2317	4.195	1.954	365	11.09	668	23.0	2.29	0.942	63.2	624.2	350
355	0.5100	1.030	3.180	2304	4.199	1.968	343	11.29	671	23.3	2.14	0.951	62.3	652.3	355
360	0.6209	1.034	2.645	2291	4.203	1.983	324	11.49	674	23.7	2.02	0.960	61.4	679.9	360
365	0.7514	1.038	2.212	2278	4.209	1.999	306	11.69	677	24.1	1.91	0.969	60.5	707.1	365
370	0.9040	1.041	1.861	2265	4.214	2.017	289	11.89	679	24.5	1.80	0.978	59.5	728.7	370
373.15	1.0133	1.044	1.679	2257	4.217	2.029	279	12.02	680	24.8	1.76	0.984	58.9	750.1	373.15
375	1.0815	1.045	1.574	2252	4.220	2.036	274	12.09	681	24.9	1.70	0.987	58.6	761	375
380	1.2869	1.049	1.337	2239	4.226	2.057	260	12.29	683	25.4	1.61	0.999	57.6	788	380
385	1.5233	1.053	1.142	2225	4.232	2.080	248	12.49	685	25.8	1.53	1.004	56.6	814	385
390	1.794	1.058	0.980	2212	4.239	2.104	237	12.69	686	26.3	1.47	1.013	55.6	841	390
400	2.455	1.067	0.731	2183	4.256	2.158	217	13.05	688	27.2	1.34	1.033	53.6	896	400
410	3.302	1.077	0.553	2153	4.278	2.221	200	13.42	688	28.2	1.24	1.054	51.5	952	410
420	4.370	1.088	0.425	2123	4.302	2.291	185	13.79	688	29.8	1.16	1.075	49.4	1010	420
430	5.699	1.099	0.331	2091	4.331	2.369	173	14.14	685	30.4	1.09	1.10	47.2		430



الجمهورية الجزائرية الديمقراطية الشعبية  
وزارة التعليم العالي والبحث العلمي  
جامعة الشهيد حمه لخضر الوادي  
كلية التكنولوجيا  
قسم هندسة الطرائق والصناعات البتر وكيميائية



## Document autorisé

### Transfert thermique et Echangeurs de chaleur & Phénomène de Transfert II

Module : **UEM1.1** Année : 21/20 Spécialité : .....Groupe : ..... Durée : 60 min

Nom et prénom : .....: الاسم واللقب: ..... Matricule: .....

Continued

Temperature, $T$ (K)	Pressure, $p$ (bars) <sup>b</sup>	Specific Volume (m <sup>3</sup> /kg)		Heat of Vaporization, $h_{fg}$ (kJ/kg)	Specific Heat (kJ/kg · K)		Viscosity (N · s/m <sup>2</sup> )		Thermal Conductivity (W/m · K)		Prandtl Number		Surface Tension, $\sigma_f \cdot 10^3$ (N/m)	Expansion Coefficient, $\beta_f \cdot 10^6$ (K <sup>-1</sup> )	Temperature, $T$ (K)
		$v_f \cdot 10^3$	$v_g$		$c_{p,f}$	$c_{p,g}$	$\mu_f \cdot 10^6$	$\mu_g \cdot 10^6$	$k_f \cdot 10^3$	$k_g \cdot 10^3$	$Pr_f$	$Pr_g$			
440	7.333	1.110	0.261	2059	4.36	2.46	162	14.50	682	31.7	1.04	1.12	45.1	—	440
450	9.319	1.123	0.208	2024	4.40	2.56	152	14.85	678	33.1	0.99	1.14	42.9	—	450
460	11.71	1.137	0.167	1989	4.44	2.68	143	15.19	673	34.6	0.95	1.17	40.7	—	460
470	14.55	1.152	0.136	1951	4.48	2.79	136	15.54	667	36.3	0.92	1.20	38.5	—	470
480	17.90	1.167	0.111	1912	4.53	2.94	129	15.88	660	38.1	0.89	1.23	36.2	—	480
490	21.83	1.184	0.0922	1870	4.59	3.10	124	16.23	651	40.1	0.87	1.25	33.9	—	490
500	26.40	1.203	0.0766	1825	4.66	3.27	118	16.59	642	42.3	0.86	1.28	31.6	—	500
510	31.66	1.222	0.0631	1779	4.74	3.47	113	16.95	631	44.7	0.85	1.31	29.3	—	510
520	37.70	1.244	0.0525	1730	4.84	3.70	108	17.33	621	47.5	0.84	1.35	26.9	—	520
530	44.58	1.268	0.0445	1679	4.95	3.96	104	17.72	608	50.6	0.85	1.39	24.5	—	530
540	52.38	1.294	0.0375	1622	5.08	4.27	101	18.1	594	54.0	0.86	1.43	22.1	—	540
550	61.19	1.323	0.0317	1564	5.24	4.64	97	18.6	580	58.3	0.87	1.47	19.7	—	550
560	71.08	1.355	0.0269	1499	5.43	5.09	94	19.1	563	63.7	0.90	1.52	17.3	—	560
570	82.16	1.392	0.0228	1429	5.68	5.67	91	19.7	548	76.7	0.94	1.59	15.0	—	570
580	94.51	1.433	0.0193	1353	6.00	6.40	88	20.4	528	76.7	0.99	1.68	12.8	—	580
590	108.3	1.482	0.0163	1274	6.41	7.35	84	21.5	513	84.1	1.05	1.84	10.5	—	590
600	123.5	1.541	0.0137	1176	7.00	8.75	81	22.7	497	92.9	1.14	2.15	8.4	—	600
610	137.3	1.612	0.0115	1068	7.85	11.1	77	24.1	467	103	1.30	2.60	6.3	—	610
620	159.1	1.705	0.0094	941	9.35	15.4	72	25.9	444	114	1.52	3.46	4.5	—	620
625	169.1	1.778	0.0085	858	10.6	18.3	70	27.0	430	121	1.65	4.20	3.5	—	625
630	179.7	1.856	0.0075	781	12.6	22.1	67	28.0	412	130	2.0	4.8	2.6	—	630
635	190.9	1.935	0.0066	683	16.4	27.6	64	30.0	392	141	2.7	6.0	1.5	—	635
640	202.7	2.075	0.0057	560	26	42	59	32.0	367	155	4.2	9.6	0.8	—	640
645	215.2	2.351	0.0045	361	90	—	54	37.0	331	178	12	26	0.1	—	645
647.3 <sup>c</sup>	221.2	3.170	0.0032	0	∞	∞	45	45.0	238	238	∞	∞	0.0	—	647.3 <sup>c</sup>

<sup>a</sup>Adapted from Reference 22.

<sup>b</sup>1 bar = 10<sup>5</sup> N/m<sup>2</sup>.

<sup>c</sup>Critical temperature.